



# 2.22

AABD

## DOUBLE AIR BOOT



### Description

The 2.22 (AABD) diffusers are designed to be fitted to recessed fluorescent light fittings. They may also be used in conjunction with a ceiling T-Bar system.

Full details of the light fittings must be provided to ensure the correct interface of the light with the air boot. This is essential to ensure optimum air distribution performance is obtained from the combination.

Insulated versions of the diffuser plenum are not insulated at the ends.

Three basic types of blade and slot width provide air flow direction of 90° up to 180°.

All diffusers are manufactured from galvanised sheet steel and aluminium blades which may be adjusted via the outlet slot.

### Australian standard

The 2.22 diffuser complies with the requirements of the Australian Standard AS 2946 - 1987

### Finish

All visible surfaces are painted flat black.

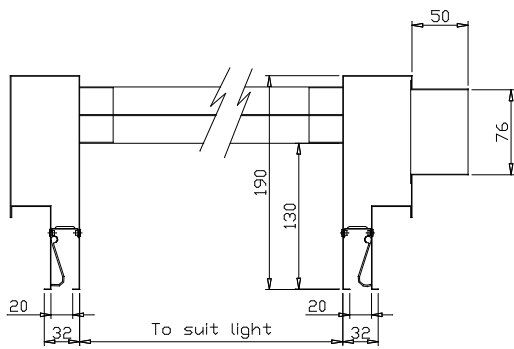

**Type A - double sided**  
- 20 mm slot  
- 0 to 90° deflection

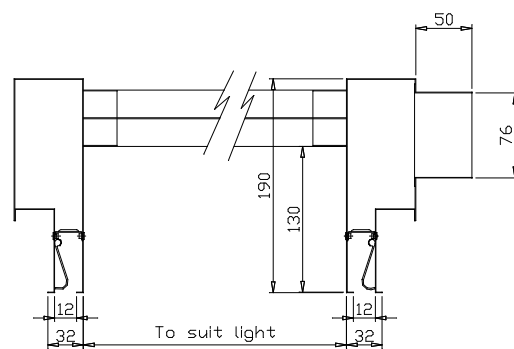

**Type B - double sided**  
- 12 mm slot  
- 0 to 90° deflection

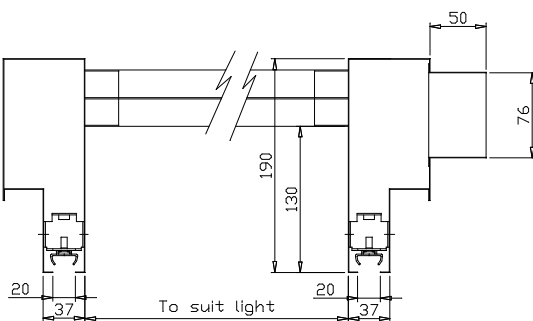

**Type C - double sided**  
- 20 mm slot  
- 0 to 180° deflection

**Note!** These sizes are available as standard products. Variations are available upon request. Contact Bradflo with your specific requirements.

### Sound data

NR levels for the grille may be determined from the engineering graph.

### Sound power level $L_w$

The generated sound power level  $L_w$  dB is calculated by adding the correction factor  $K_{ok}$  (see table below) to the sound level NR dB according to the formula:

$$L_w = NR + K_{ok}$$

No. Slots	Frequency (cycles per second)						
	125	250	500	1000	2000	4000	8000
A							
Double	+10	+15	+12	+1	-1	-16	-25
B							
Double	+10	+7	+7	-8	-2	-15	-26
C							
Double	+14	+17	+9	+5	-2	-16	-27
Tol +/-	2	2	2	2	2	2	2

Correction factor  $K_{ok}$

### Sound absorption $\Delta L$ dB

The sound absorption shown relates to a reduction of the sound power level calculated from duct to room. The end reflection is included in the values.

No. Slots	Frequency (cycles per second)						
	125	250	500	1000	2000	4000	8000
A							
Double	13	9	4	0	0	0	0
B							
Double	13	9	4	0	0	0	0
C							
Double	13	9	4	0	0	0	0
Tol +/-	2	2	2	2	2	2	2

### Air pattern

(with isothermal air supply)

$$b_h = L_{0.3} \times 0.02 + \text{length}$$

$$L_{bh} = L_{0.3} \times 0.6$$

$$b_v = L_{0.3} \times 0.08$$

$$L_{bv} = L_{0.3} \times 0.5$$

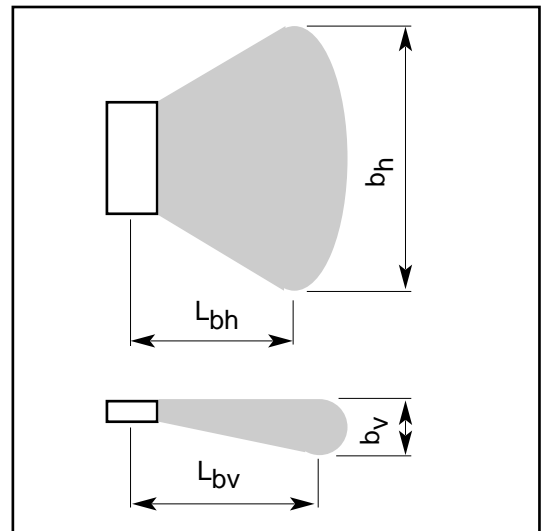

# 2.22

AABD

## DOUBLE AIR BOOT



### Engineering Graphs

Throws shown are to a terminal velocity of 0.60 m/s and 0.30 m/s.

Terminal velocity	Approximate air velocity in room
0.60 m/s	0.30 m/s
0.30 m/s	0.15 m/s

AABD Type A

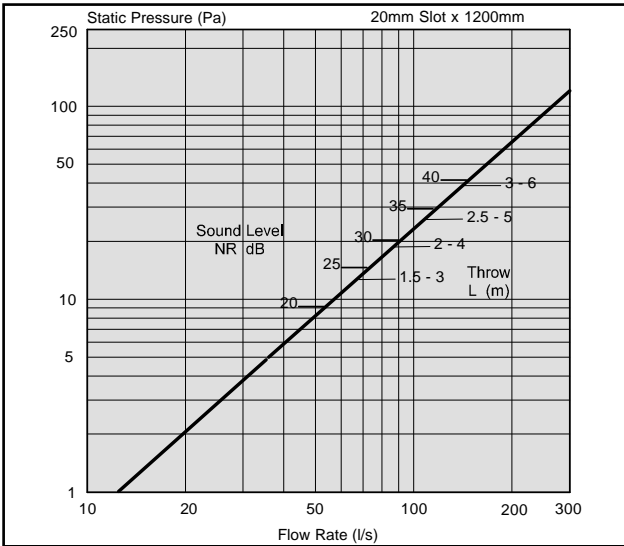

AABD Type B

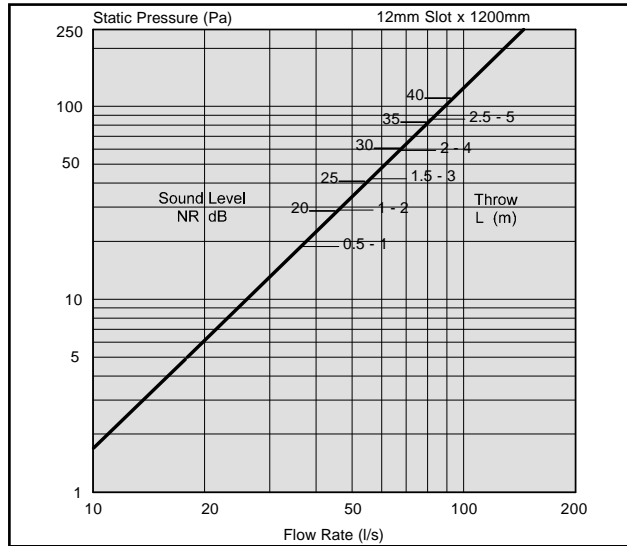

These graphs are for selection only and should not be used for commissioning.

AABD Type C

