

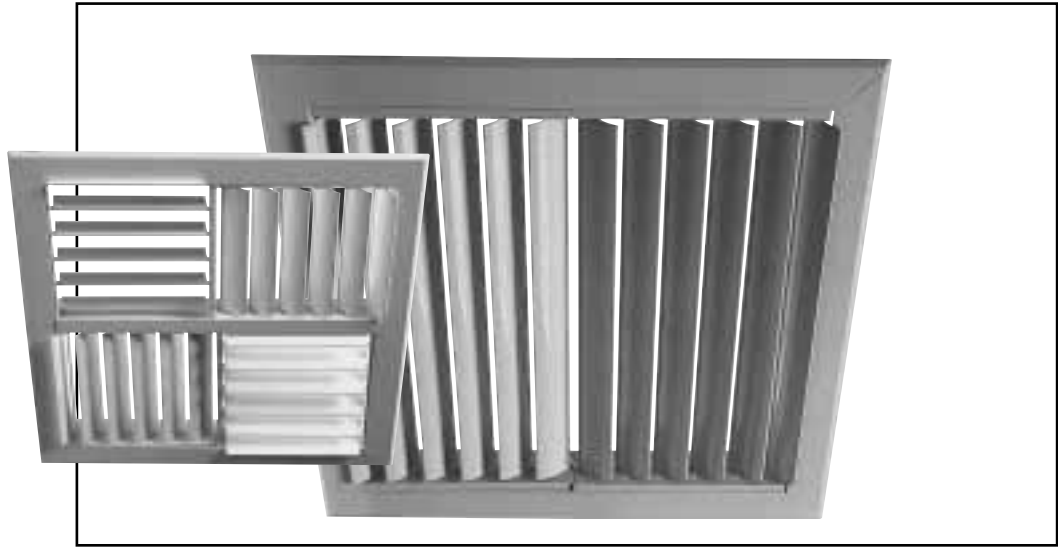

# CURVED BLADE REGISTER

**1.41**  
ACB



### Selection Guide

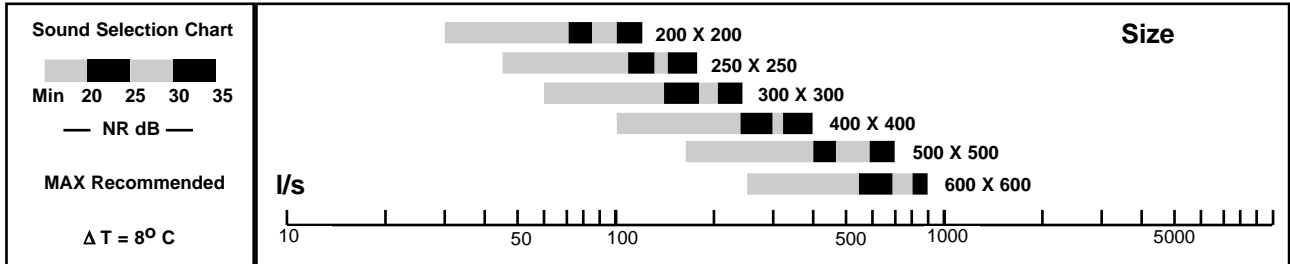

### Ordering procedure

Using the chart below select your requirement and substitute the underscored text below.

**Type..X..Y** (X & Y are the nominal neck sizes of the grille, see overleaf.)

**Example:** If your requirement is for a 12" x 12" (300mm x 300mm) curved blade (2 way blow) grille, the ordering code would be ACB2B1212. {When ordering it is not necessary to include the periods [..]}

### Specials:

Special sizes are available upon request. Please contact your nearest Bradflo office.

Product Size Numbers												
"Type"	"X" Size	"Y" Size										Colour
		06 (150)	08 (200)	10 (250)	12 (300)	14 (350)	16 (400)	18 (450)	20 (500)	24 (600)		
ACB2B (2 way blow)	06 (150)											Powdercoate white Special colours
ACBMB (Multi blow)	08 (200)											
	10 (250)											
	12 (300)											
	14 (350)											
	16 (400)											
	18 (450)											
	20 (500)											
Special	24 (600)											

Note! Shaded areas indicate standard product.

# 1.41

ACB

## CURVED BLADE REGISTER



### Description

Model 1.41 (ACB) grilles have been designed for supply air situations and are especially suited for evaporative cooling systems.

These grilles are available in 1, 2, 3 or 4 way air flow patterns. The ACB2B may be configured to a 1 or 2 way blow and the ACBMB may be configured to all directions above. Note that when using a neck reducer (ANAG) the configuration of the ACBMB must be carried out prior to fitting the neck reducer. The blade profiles have been designed to provide the most efficient operation at the lowest possible sound level.

The main components of the grille are manufactured from extruded aluminium.

### Finish

Standard finish is white electrostatic powdercoat. There are also 15 other colours available at no additional cost.

Contact your local Bradflo branch for any special requirement you may have.

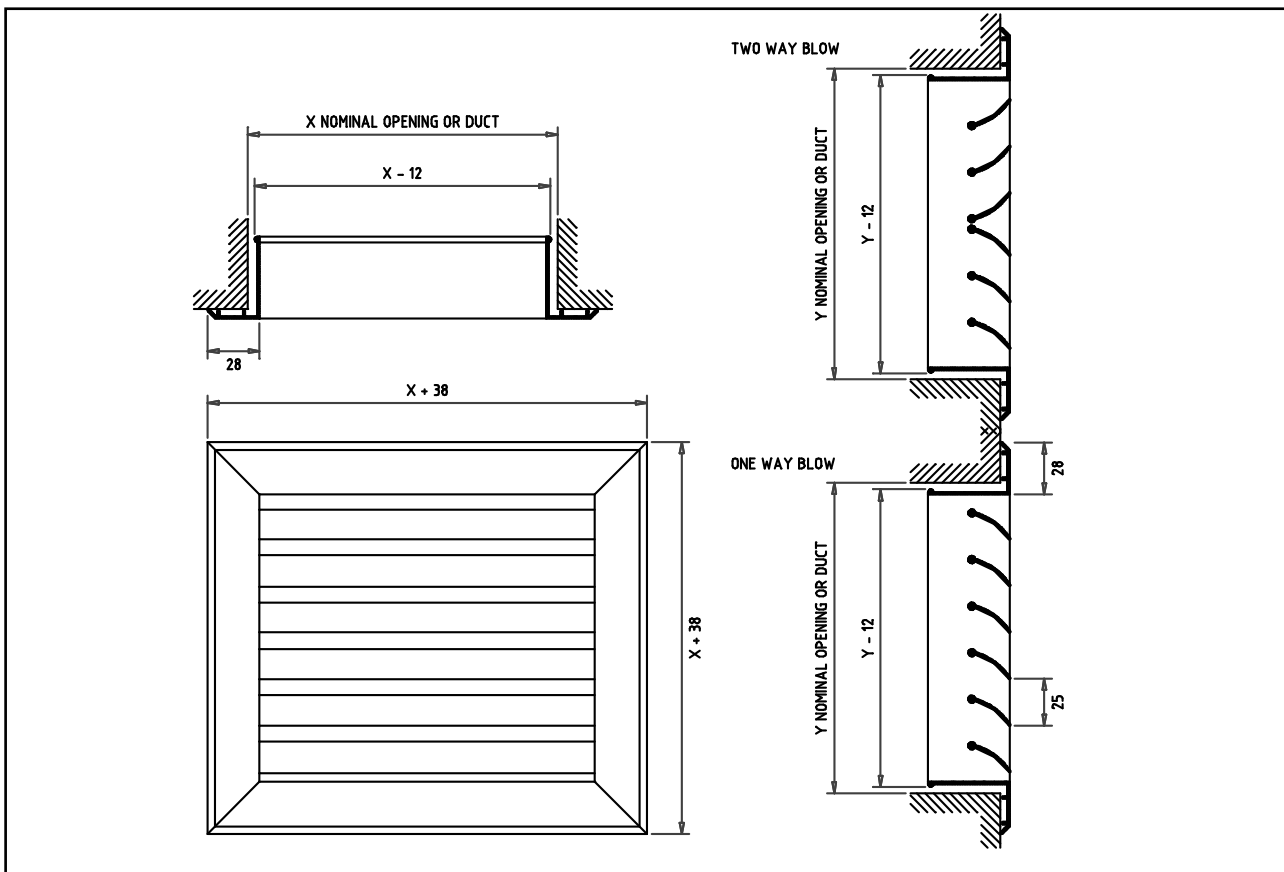



# CURVED BLADE REGISTER

1.41

ACB

## Engineering Graphs

Throws shown are to a terminal velocity of 0.60 m/s and 0.30 m/s. Throw is given for equal slots in each direction.

Terminal velocity	Approximate air velocity in room
0.60 m/s 0.30 m/s	0.30 m/s 0.15 m/s

### Performance data (1-way blow)

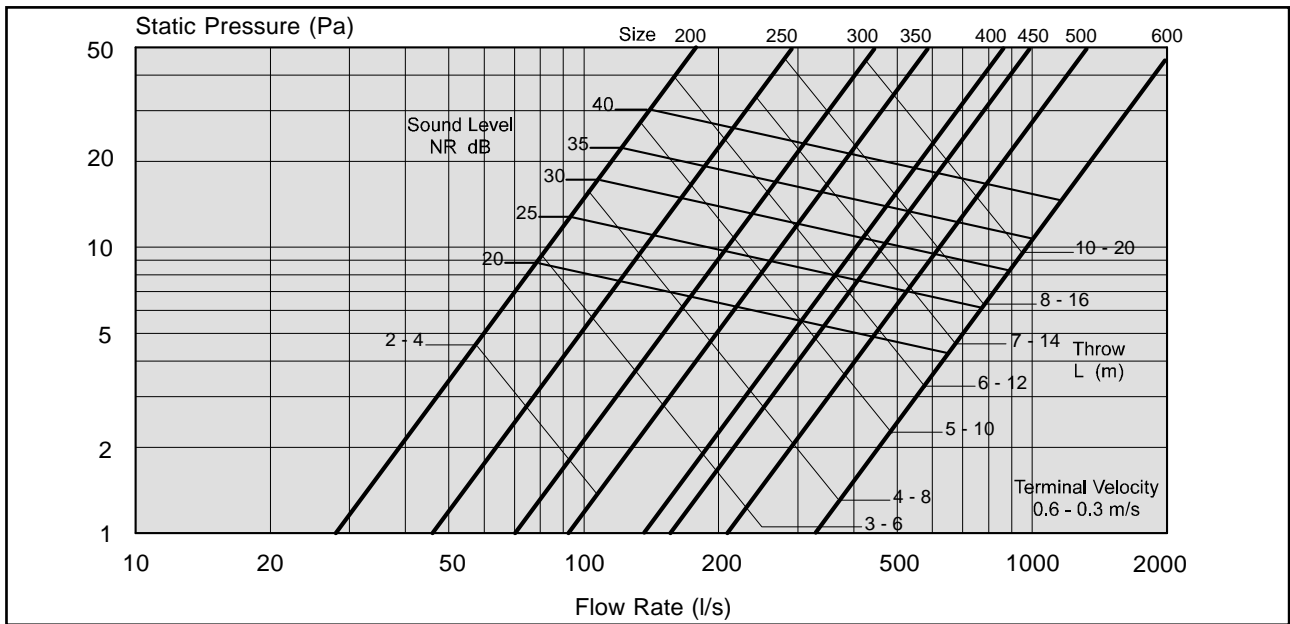

### Performance data (2-way blow)

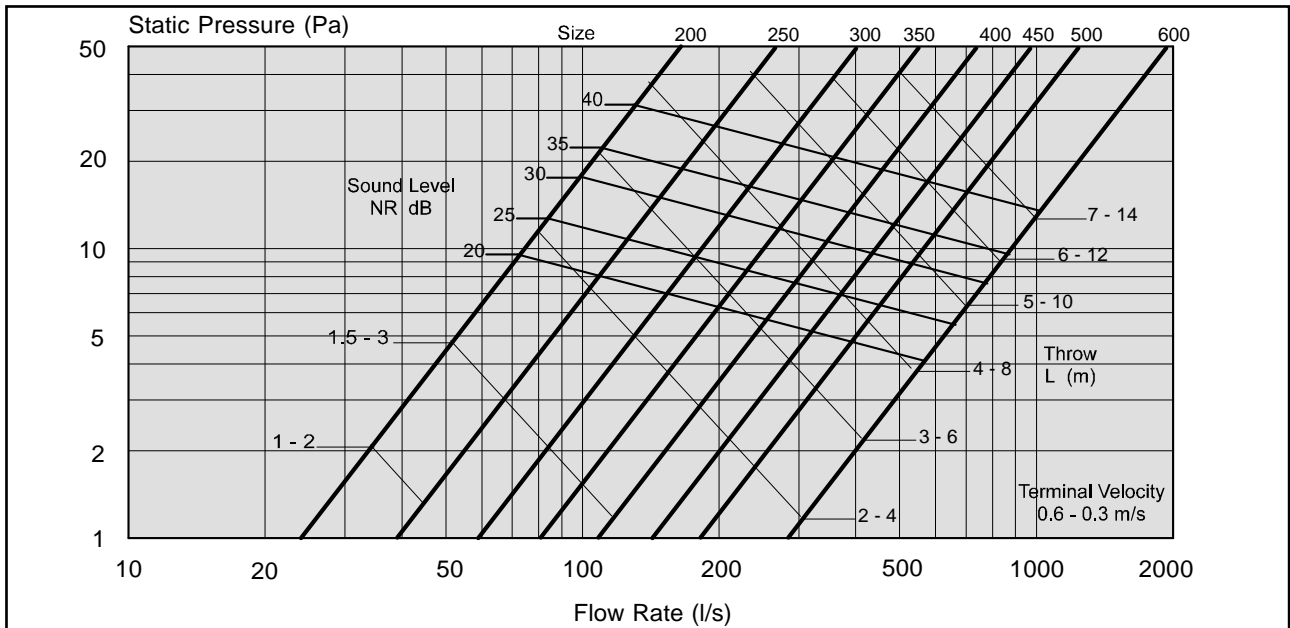

These graphs are for selection only and should not be used for commissioning

# 1.41

ACB

## CURVED BLADE REGISTER



### Engineering Graphs

Throws shown are to a terminal velocity of 0.60 m/s and 0.30 m/s. Throw is given for equal slots in each direction.

Terminal velocity	Approximate air velocity in room
0.60 m/s 0.30 m/s	0.30 m/s 0.15 m/s

### Performance data (3-way blow)

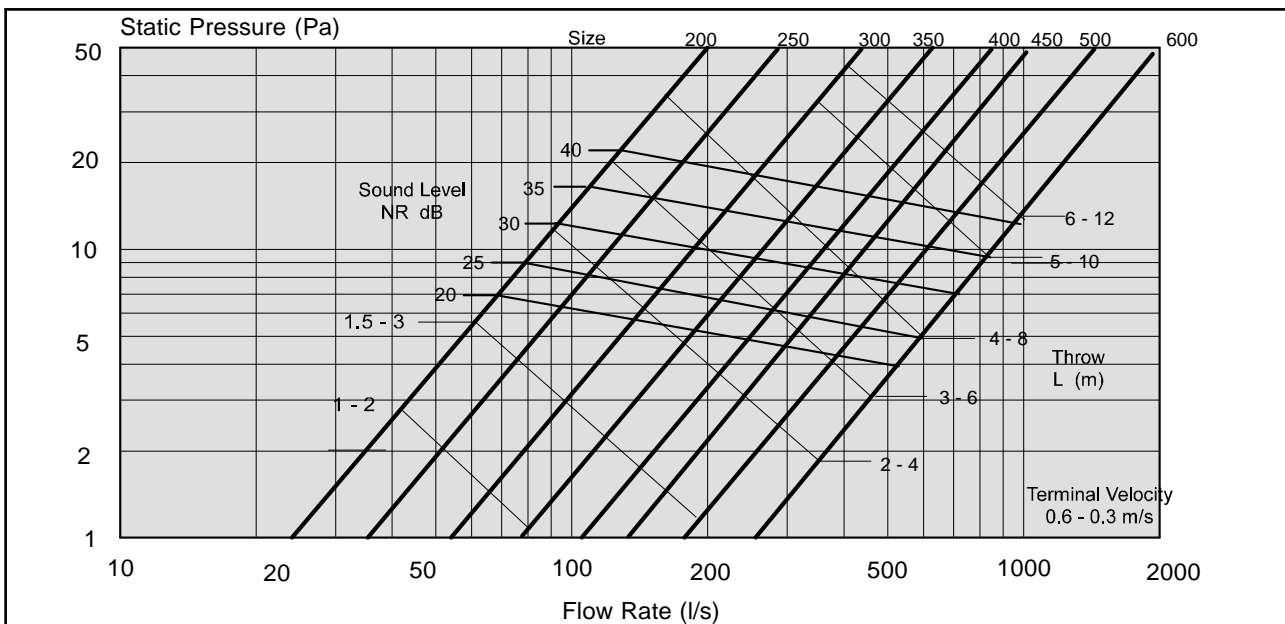

### Performance data (4-way blow)

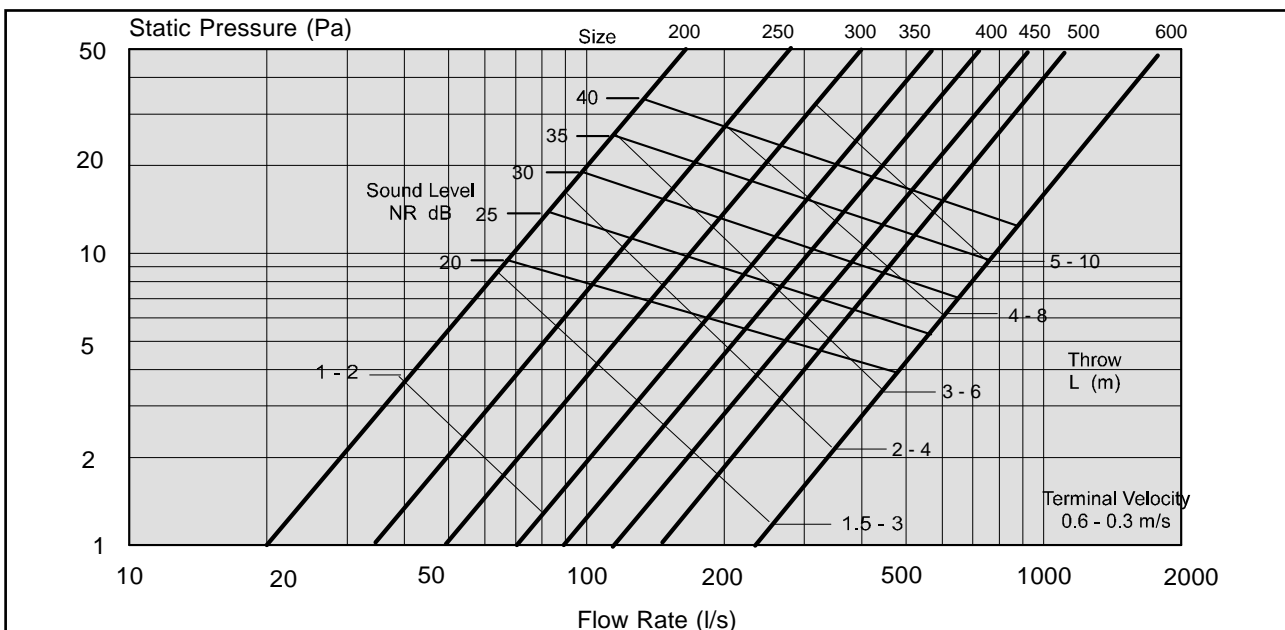

These graphs are for selection only and should not be used for commissioning

### Air pattern configuration

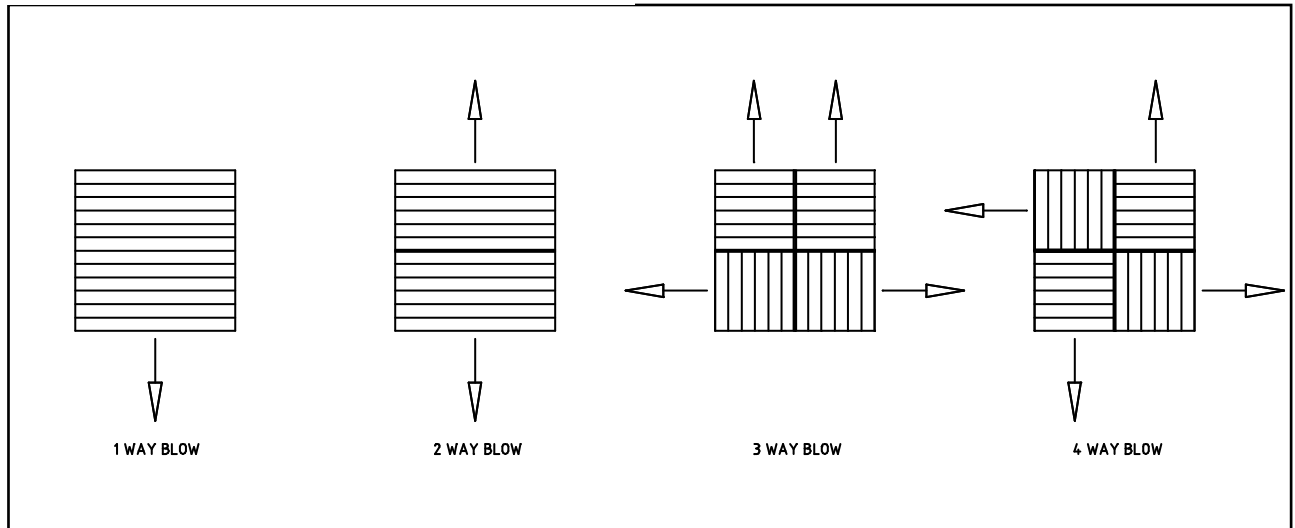

### Sound data

NR levels for the grille may be determined from the engineering graph.

### Sound power level $L_w$

The generated sound power level  $L_w$  dB is calculated by adding the correction factor  $K_{Ok}$  (see table below) to the sound level NR dB according to the formula:

$$L_w = NR + K_{Ok}$$

	Frequency (cycles per second)						
Size	125	250	500	1000	2000	4000	8000
All	+16	+14	+12	+6	-1	-6	-8
Tol +/-	2	2	2	2	2	2	2

Correction factor  $K_{Ok}$

### Air pattern

(with isothermal air supply)

$$b_h = L_{0.3} \times 0.03$$

$$L_{bh} = L_{0.3} \times 0.5$$

$$b_v = L_{0.3} \times 0.05$$

$$L_{bv} = L_{0.3} \times 0.4$$

